

highlights

spring

2016





EOS LED CIRCULAR

Minimalism. Style. High visual comfort.

The circular version of EOS LED outstands with an added detail in the housing - RGB LED strip, which creates a pleasant and romantic atmosphere in the ambience. When switched on, it delivers a perception of homogenous light floating in the air. Options: EOS Cloud, EOS Sky, with or without RGB strip.

APOLLO LED

First impression counts.

Apollo LED astonishes with its 1200mm uniformly illuminated circular shape. The suspended direct/indirect luminaire will fascinate visitors when entering lobbies, foyers, lounges, reception areas and other spacious ambiances, adding character and enhancing the room.



new



NURIEL LED

Soft light distribution and glare-free light for general and task area lighting.

With NURIEL LED you will see the light, but not the light-source, which will create a uniform distribution of light with no shadows and dark spots.

Nordic design. Designed by Kai Piippo for Annell.
Superior performance. Manufactured and produced by Led Luks.



Plain LED

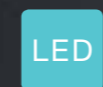

Elegance of simplicity, efficiency of LED technology.

With a Nordic approach to design, balanced with functionality and aesthetics, the well renowned Swedish lighting designer Kai Piippo created Plain LED. Defined with elegant straight lines, it adds a tasteful expression to your office. The suspended direct/indirect LED luminaire produces a medium beam downlight and a wide beam uplight, which adds perfect light and ambience to your office environment. Lower UGR ensures excellent glare control.

- direct/indirect LED luminaire
- slim, suspended luminaire with elevated light opening
- two lengths 1300mm and 1600mm
- structure lacquered matt white
- combination of different modules to continuous light-lines system



EOS

LED

Minimalism. Style. High visual comfort.

The luminaire that makes your office a place of comfort and gives a stylish touch to your interior. Emitting light both up to the ceiling and down to the workspace, it supplies homogenous glare-free light and maximum visual comfort. It is a perfect fixture for conference rooms, open offices, lobbies, and other applications where you want to make an impact.



LED

- high quality aluminium housing with black or white powder coated finish
- dimmable DALI



- options: EOS Sky (transparent panel) and EOS Cloud (PMMA Prismatic sheet)



LED



Kyra LED impresses with its up to 3 meters long elegant housing, bringing you more quality light and cost-savings. Due to its length and low ugr, it delivers a homogenous and efficient distribution of light and enables less luminaires per room. Thus, it is most suitable for open-space offices, corridors, foyers, conference areas, classrooms and other spacious ambiances.

- direct/indirect LED luminaire
- available in different dimensions: 1200, 1500, 2400 and 3000mm
- high quality aluminium housing with black, white or grey powder coated finish
- low glare

KYRA

LED

Infinite beam
of light.



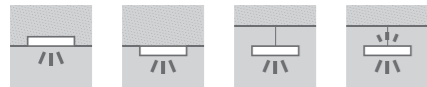

ILO LED FAMILY

Modular light-line system

With its modular design, ILO LED can be used as an individual fixture or as a combination of modules put together in lighting systems. With its straight lines it can be whether an elegant solution for representative offices as well as an energy-efficient solution for shops, retail areas, corridors and other applications. Thanks to Dynamic White Technology it has a strong positive affect to human biorhythm, health, effectiveness and concentration at work.

- from 2000 to 3000 lm/m
- combination of modules in continuous lines, corner or other special positions
- black, white or gray painted
- from 21 to 35 W/m
- high quality aluminum profile
- dimmable DALI

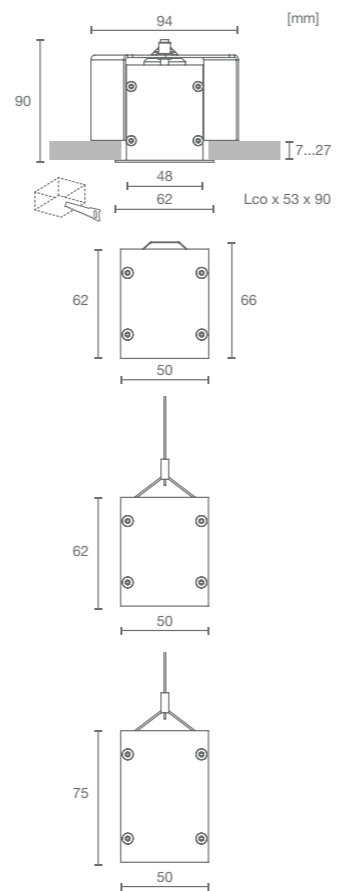

recessed

ceiling



With its modular design, ILO LED can be used as an individual fixture or as a combination of modules put together in lighting systems. With its straight lines it can be whether an elegant solution for representative offices as well as an energy-efficient solution for shops, retail areas, corridors and other applications. Thanks to Dynamic White Technology it has a strong positive affect to human biorhythm, health, effectiveness and concentration at work.

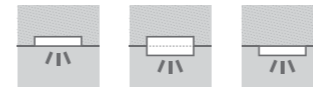

ALVA LED

Premium lighting environment for sustainable offices

ALVA LED represents a SMART combination of design and technology achieving the best possible light quality even when illuminating the most demanding lighting areas. Its slim design makes it an ideal solution for tight ceiling conditions and a perfect option to expose the place's architecture.

- fine prismatic PMMA optic for perfect glare reduction and no "rainbow effect"
- dimmable DALI

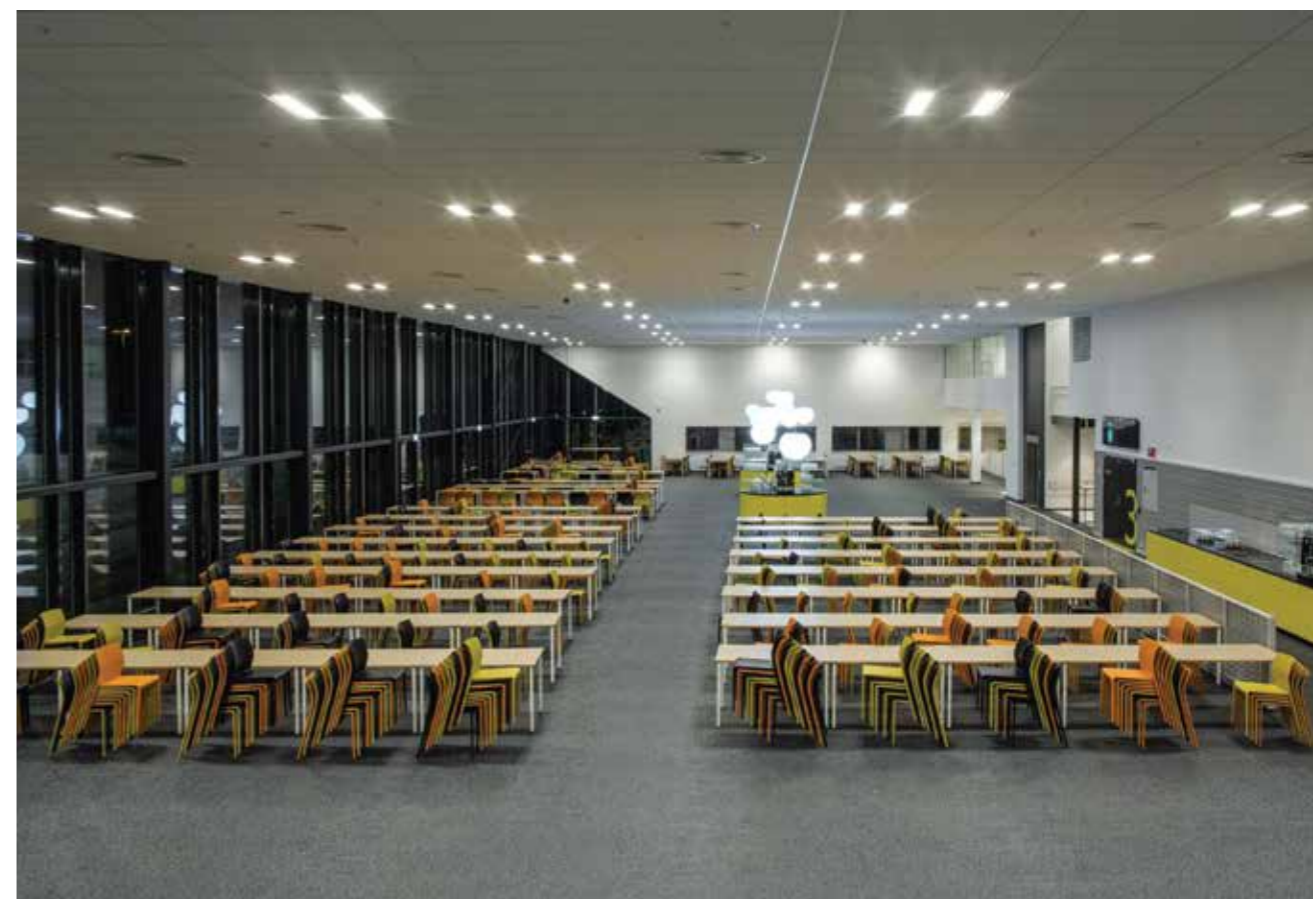



ARUN LED

Light that supports performance and well-being

ARUN LED recessed luminaire produces biologically effective light. Due to Dynamic White Technology not only has a strong positive affect to human biorhythm, health and sleeping quality, but also significantly influences the effectiveness and concentration at work.

- microprismatic optic in opal PMMA diffuser provides optimal, uniform and glare-free light with no visible LED hot spots and excellent light transmission
- dimmable DALI



NOOR LED

Premium lighting environment for sustainable offices

NOOR LED downlight luminaire stands out with its clear design and outstanding performances. Being available in four sizes and with an affordable price it is a perfect choice for many ambiances, especially for shops, corridors, offices, hotels, restaurants, libraries, residential interiors and as a general lighting. With its low profile housing fits perfectly to shallow mounting depths in suspended ceilings.

- dimmable DALI on request
- IP 44 on request





HYPERION LED

Professional high-bay luminaire, best choice for industry and sport

HYPERION LED is suitable for suspended or ceiling installation. It offers sustainable, high-efficient lighting for industrial plants, warehouses and sport areas. Different optics, housing sizes, light output options and many accessories for easy and precise installation and save operation make it a perfect choice for various specific applications.

- ambient operating temperature -25 to +50°C
- light output from 8400 to 35000 lm
- IP65 degree of protection
- up to 137 lm/W



Coming soon
Top price-performance
solution

Hyperion ALU

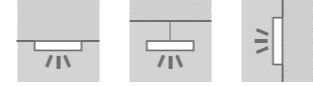

HATOR LED

Durable and highly efficient moisture-proof luminaire

HATOR LED represents a high quality, excellent energy efficient and maintenance free moisture-proof luminaire. Its robust housing makes it the best choice for many applications, such as: multi-story car parks, industrial plants, warehouses, storage and cold storage rooms, loading bays, corridors, agricultural buildings and other facilities with complex ambient conditions.

- temperature range from -25 to 35 C
- up to 129lm/W





www.ledluks.com

Led luks d.o.o.

Mednarodni prehod 6, Vrtojba

SI-5290 Šempeter pri Gorici

Slovenia